

# San Ace 172GP 9GP type

## G Proof Fan

### ■ Features

#### Highly Resistant to G-Forces

This fan can withstand g-forces of 75 g for 1000 hours.\*

#### Low Noise and High Energy Efficiency

The PWM control function enables the external control of fan speed, contributing to lower noise and higher energy efficiency of devices.

\* Measured with our g-force testing machine. g = Acceleration of gravity = 9.8 m/s<sup>2</sup>



∅172×150×51mm

### ■ Specifications

The following nos. **have PWM controls, pulse sensors.**

Model no.	Rated voltage [V]	Operating voltage range [V]	PWM duty cycle* [%]	Rated current [A]	Rated input [W]	Rated speed [min <sup>-1</sup> ]	Max. airflow [m <sup>3</sup> /min] [CFM]	Max. static pressure [Pa] [inchH <sub>2</sub> O]	SPL [dB(A)]	Operating temperature [°C]	Expected life [h]
9GP5724P5H001	24	16 to 30	100	5.00	120	8000	12.3 434	1000 4.02	77	-20 to +70	40000/60°C (70000/40°C)
			20	0.50	12.0	3000	4.6 162	175 0.70	51		
9GP5748P5G001	48	36 to 72	100	5.00	240	10500	16.1 568	1600 6.43	83		
			20	0.41	19.7	3700	5.6 198	250 1.01	57		

\* PWM frequency: 25 kHz. Fan does not rotate when PWM duty cycle is 0%.

Models with the following sensor specifications are also available as options: Without sensor Lock sensor

### ■ Common Specifications

- Material ..... Frame: Aluminum (Black coating), Impeller: Plastics (Flammability: UL 94V-1)
- Expected life ..... Refer to specifications  
(L10: Survival rate: 90% at 60°C, rated voltage, and continuously run in a free air state)  
Expected life at 40°C ambient is just reference value.
- Motor protection system ..... Current blocking function and reverse polarity protection
- Dielectric strength ..... 50/60 Hz, 500 VAC, 1 minute (between lead conductor and frame)
- Sound pressure level (SPL) ..... Expressed as the value at 1 m from air inlet side
- Operating temperature ..... Refer to specifications (Non-condensing)
- Storage temperature ..... -30 to +70°C (Non-condensing)
- Lead wire ..... ⊕Red ⊖Black Sensor: Yellow Control: Brown
- Mass ..... Approx. 880 g
- G-force tolerance ..... 75 g for 1000 hours (Measured with our g-force testing machine)

## Airflow - Static Pressure Characteristics

- PWM duty cycle

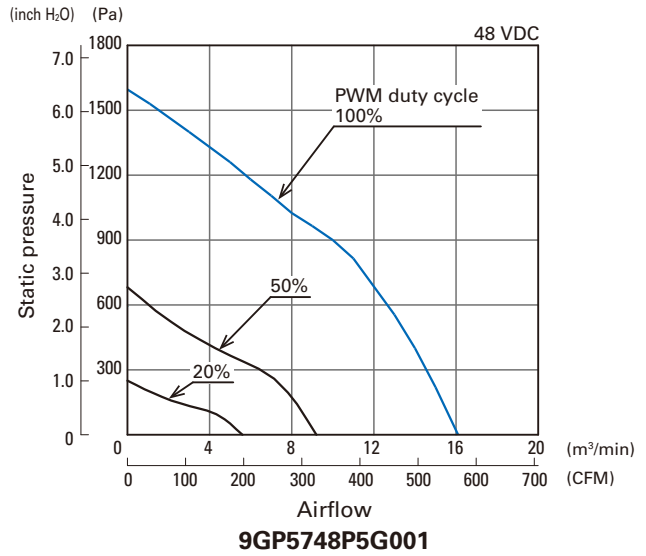
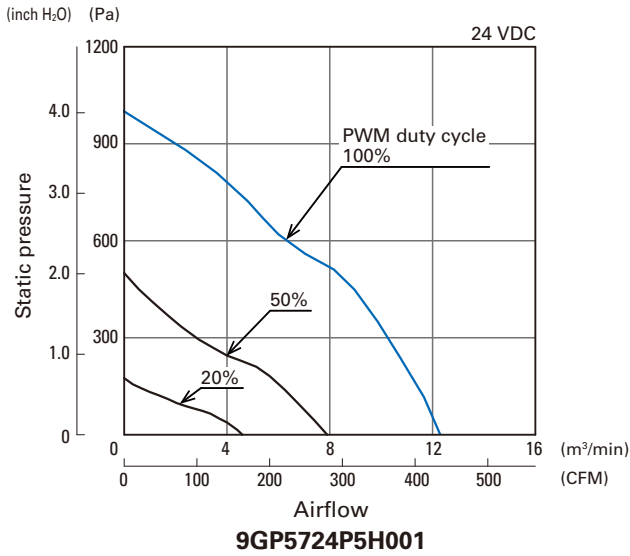

- Operating voltage range

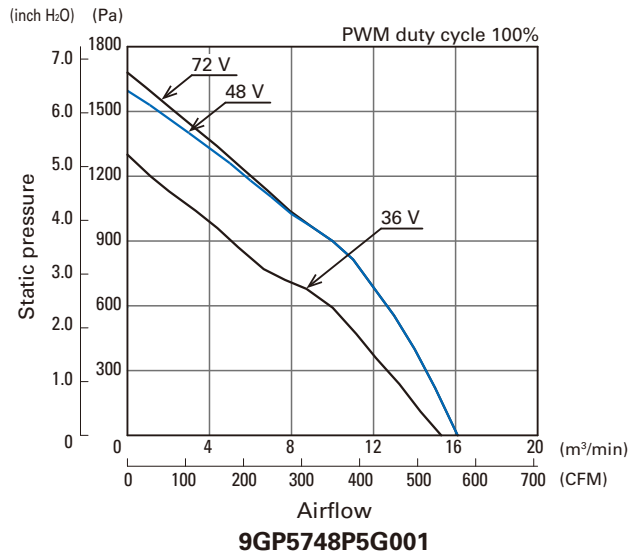
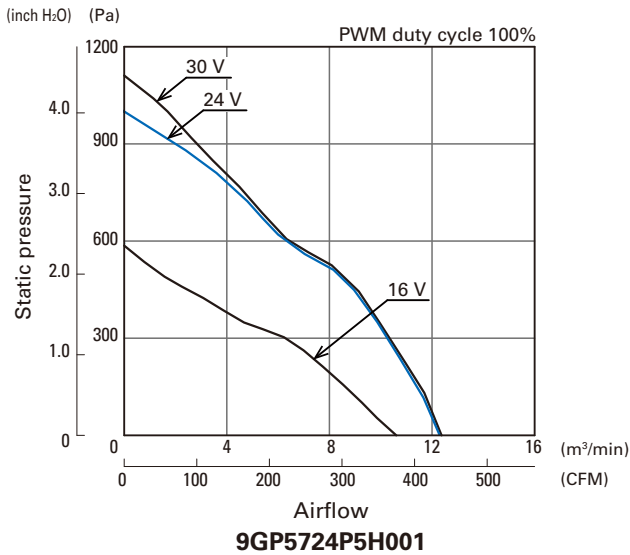

## PWM Duty - Speed Characteristics Example

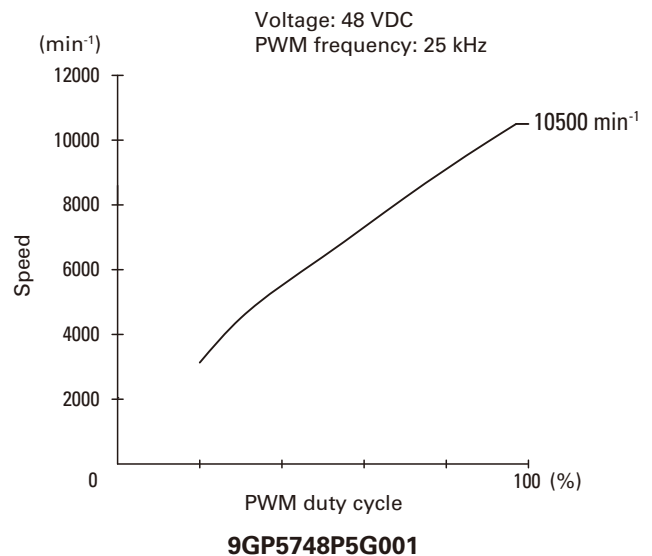
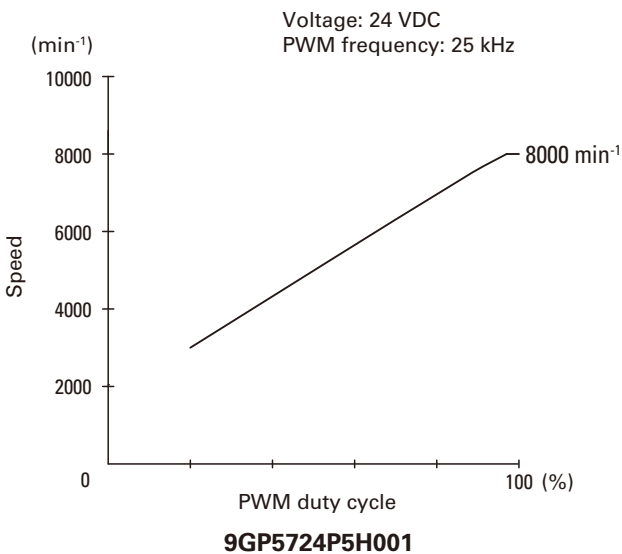

**PWM Input Signal Example**

Input signal waveform

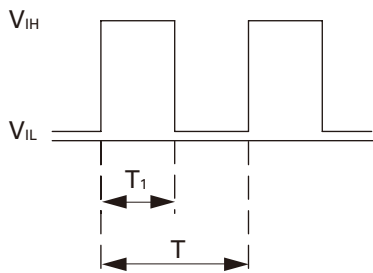

$V_{IH} = 4.75 \text{ to } 5.25 \text{ V}$     $V_{IL} = 0 \text{ to } 0.4 \text{ V}$   
 PWM duty cycle (%) =  $\frac{T_1}{T} \times 100$    PWM frequency 25 (kHz) =  $\frac{1}{T}$   
 Current source ( $I_{source}$ ) = 1 mA max. (when control voltage is 0 V)  
 Current sink ( $I_{sink}$ ) = 1 mA max. (when control voltage is 5.25 V)  
 Control terminal voltage = 5.25 V max. (when control terminal is open)

When the control terminal is open,  
 fan speed is the same as when PWM duty cycle is 100%.  
 Either TTL input, open collector or open drain can be used for  
 PWM control input signal.

**Example of Connection Schematic**

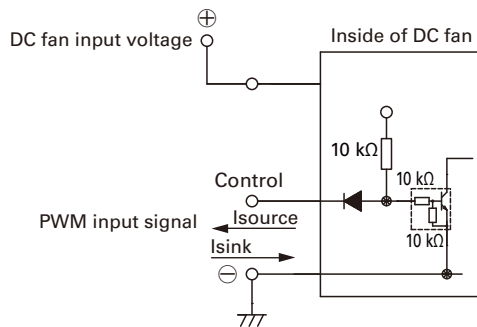

**Specifications for Pulse Sensors**

Output circuit: Open collector

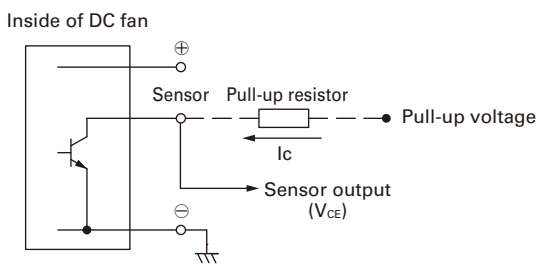

**Rated voltage 24 V fan**  
 $V_{CE} = +36 \text{ V max.}$   
 $I_C = 10 \text{ mA max.}$  [ $V_{OL} = V_{CE} \text{ (SAT)} = 1 \text{ V max.}$ ]  
**Rated voltage 48 V fan**  
 $V_{CE} = +72 \text{ V max.}$   
 $I_C = 10 \text{ mA max.}$  [ $V_{OL} = V_{CE} \text{ (SAT)} = 1 \text{ V max.}$ ]

Output waveform (Need pull-up resistor)

In case of steady running

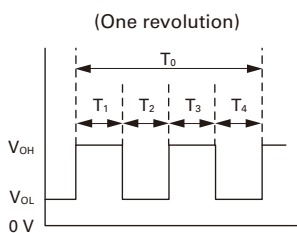

$T_{1 \text{ to } 4} \doteq (1/4) T_0$   
 $T_{1 \text{ to } 4} \doteq (1/4) T_0 = 60/4N \text{ (s)}$   
 $N = \text{Fan speed (min}^{-1}\text{)}$

## ■ Dimensions (unit: mm)

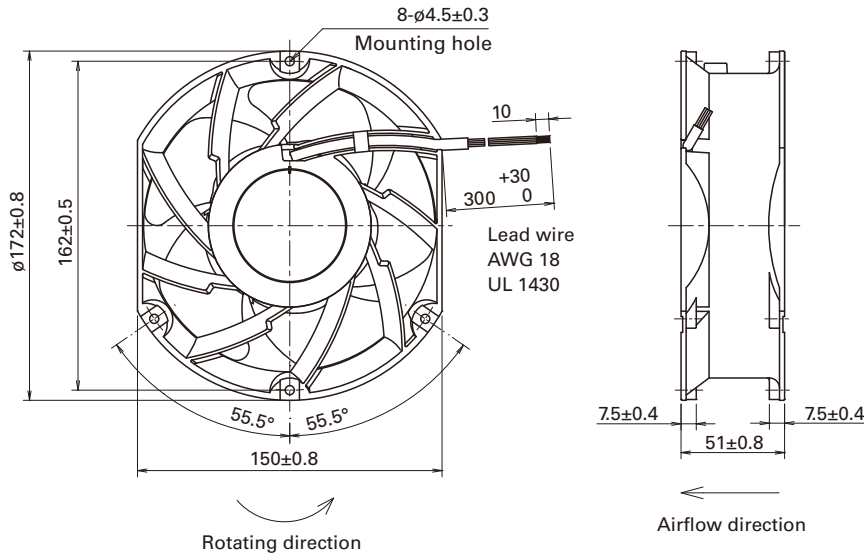

## ■ Reference Dimensions of Mounting Holes and Vent Opening (unit: mm)

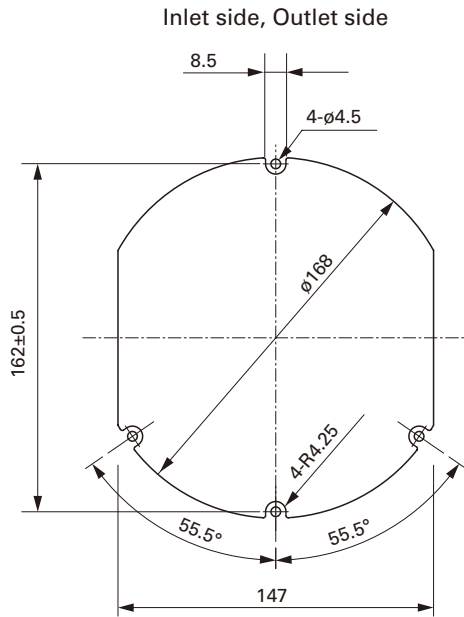

### Notice

- Please read the "Safety Precautions" on our website before using the product.
- The products shown in this catalog are subject to Japanese Export Control Law. Diversion contrary to the law of exporting country is prohibited.
- For protecting fan bearings against electrolytic corrosion near strong electromagnetic noise sources, we provide effective countermeasures such as Electrolytic Corrosion Proof Fans and EMC guards. Contact us for details.

**SANYO DENKI CO., LTD.** 3-33-1, Minami-Otsuka, Toshima-ku, Tokyo 170-8451, Japan TEL: +81 3 5927 1020

<https://www.sanyodenki.com>

The names of companies and/or their products specified in this catalog are the trade names, and/or trademarks and/or registered trademarks of such respective companies. "San Ace" is a trademark of SANYO DENKI CO.,LTD.

Specifications are subject to change without notice.

CATALOG No. C1074B001 '17.8