

San Ace140L 9LG type

Long Life Fan

Features

Long Service Life

This fan achieves an expected life as long as 180,000 hours, which is 1.8 times that of our current model⁽¹⁾.

High Airflow and High Static Pressure

This fan delivers a maximum airflow of 8.0 m³/min and maximum static pressure of 516 Pa.⁽²⁾

Compared with the current model⁽¹⁾, the maximum airflow has been increased to 1.7 times and maximum static pressure has been increased to 5.2 times.

High Energy Efficiency and Low Noise

Power consumption has been reduced by approximately 18%⁽³⁾ compared with the current model⁽¹⁾.

The PWM control function enables the external control of fan speed, contributing to the lower noise and higher energy efficiency of devices.

(1) Current model: *San Ace 140L* 9L type 140 × 140 × 38 mm Long Life Fan (model no. 109L14□□H101).

(2) The values are for 9LG14□□P1A001 models, where □'s are wildcard characters.

(3) The values are for 9LG14□□P1M001 models, where □'s are wildcard characters.



140 × 140 × 38 mm

Specifications

The models listed below **have pulse sensors with PWM control function.**

Model no.	Rated voltage [V]	Operating voltage range [V]	PWM duty cycle* [%]	Rated current [A]	Rated input [W]	Rated speed [min ⁻¹]	Max. airflow [m ³ /min] [CFM]	Max. static pressure [Pa] [inchH ₂ O]	SPL [dB(A)]	Operating temperature [°C]	Expected life [h]
9LG1412P1A001	12	10.2 to 13.8	100	3.72	44.64	6900	8.0 282	516 2.07	68	-20 to +70	180000/60°C
			20	0.27	3.24	2300	2.66 93	80 0.32	39		
9LG1412P1H001			100	1.70	20.40	5200	6.0 212	300 1.20	62		
			20	0.27	3.24	2300	2.66 93	80 0.32	39		
9LG1412P1M001			100	0.60	7.20	3300	3.7 130	170 0.68	46		
			20	0.16	1.92	1300	1.45 51	26 0.10	29		
9LG1424P1A001	24	20.4 to 27.6	100	1.86	44.64	6900	8.0 282	516 2.07	68		
			20	0.17	4.08	2300	2.66 93	80 0.32	39		
9LG1424P1H001			100	0.85	20.40	5200	6.0 212	300 1.20	62		
			20	0.16	3.84	2300	2.66 93	80 0.32	39		
9LG1424P1M001			100	0.30	7.20	3300	3.7 130	170 0.68	46		
			20	0.11	2.64	1300	1.45 51	26 0.10	29		
9LG1448P1A001	48	40.8 to 55.2	100	0.92	44.16	6900	8.0 282	516 2.07	68		
			20	0.11	5.28	2300	2.66 93	80 0.32	39		
9LG1448P1H001			100	0.42	20.16	5200	6.0 212	300 1.20	62		
			20	0.11	5.28	2300	2.66 93	80 0.32	39		
9LG1448P1M001			100	0.15	7.20	3300	3.7 130	170 0.68	46		
			20	0.09	4.32	1300	1.45 51	26 0.10	29		

* PWM frequency: 25 kHz. Fan does not rotate when PWM duty cycle is 0%.

Models with the following sensor specifications are also available as options: Without Sensor Lock sensor

Common Specifications

- Material Frame: Aluminum (Black coating), Impeller: Plastic (Flammability: UL 94V-1)
- Expected life See the table below.
(L10 life: 90% survival rate for continuous operation in free air at 60°C, rated voltage)
- Motor protection system Current blocking function and reverse polarity protection
- Dielectric strength 50/60 Hz, 500 VAC, for 1 minute (between lead wire conductors and frame)
- Sound pressure level (SPL) At 1 m away from the air inlet
- Operating temperature Refer to specifications (Non-condensing)
- Storage temperature -30 to +70°C (Non-condensing)
- Lead wire ⊕ Red ⊖ Black Sensor Yellow Control Brown
- Mass Approx. 640 g

Airflow - Static Pressure Characteristics

• PWM duty cycle

• Operating voltage range

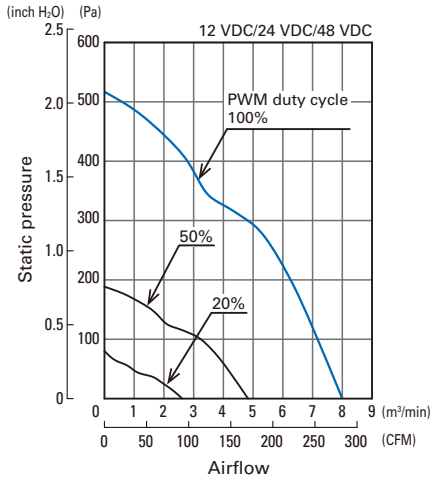

9LG1412P1A001
9LG1424P1A001
9LG1448P1A001

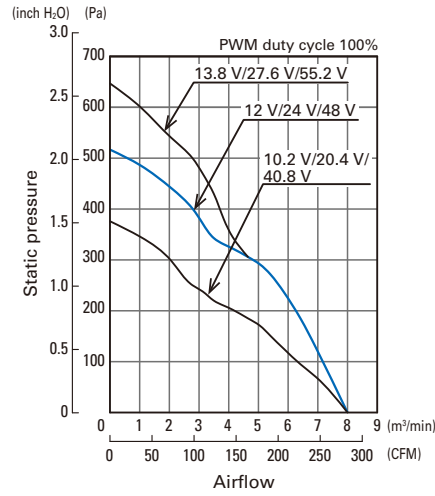

9LG1412P1A001
9LG1424P1A001
9LG1448P1A001

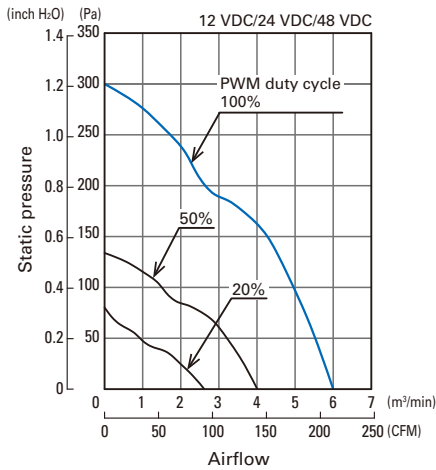

9LG1412P1H001
9LG1424P1H001
9LG1448P1H001

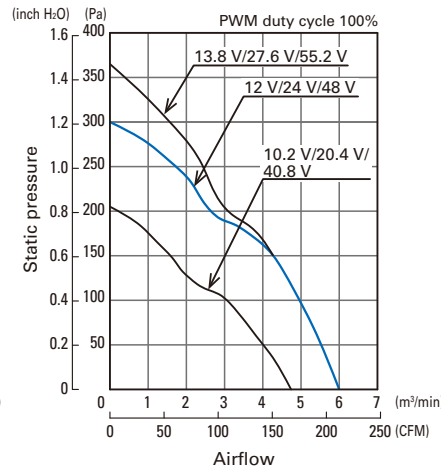

9LG1412P1H001
9LG1424P1H001
9LG1448P1H001

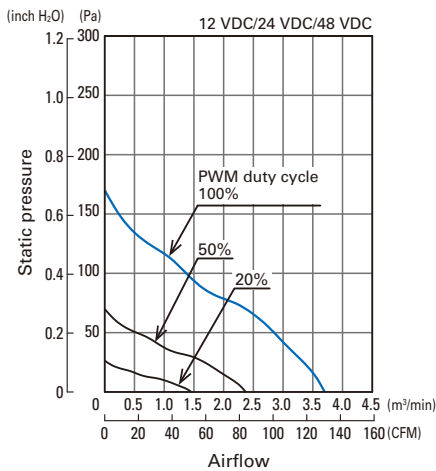

9LG1412P1M001
9LG1424P1M001
9LG1448P1M001

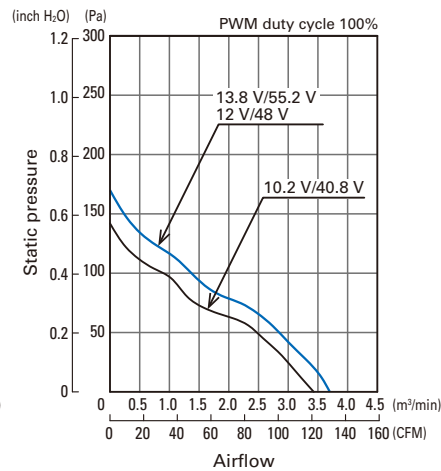

9LG1412P1M001
9LG1448P1M001

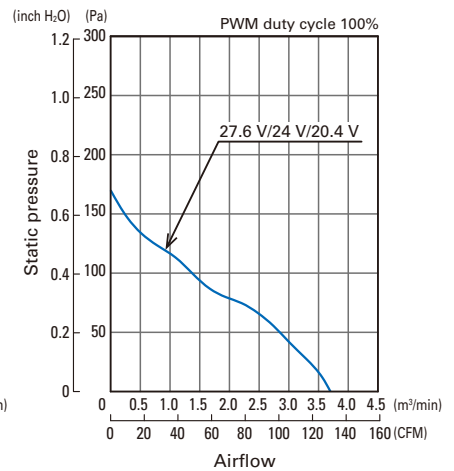

9LG1424P1M001

PWM Duty - Speed Characteristics Example

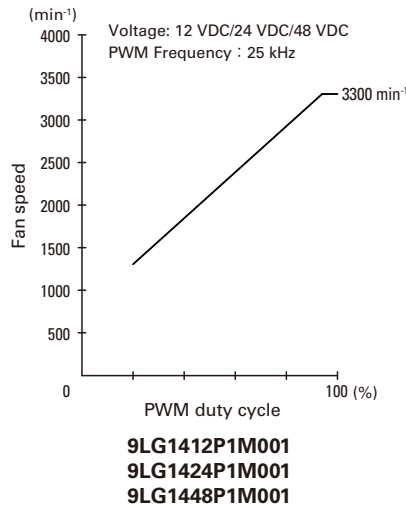
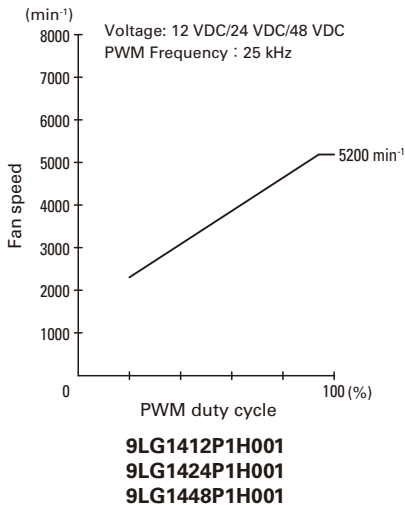
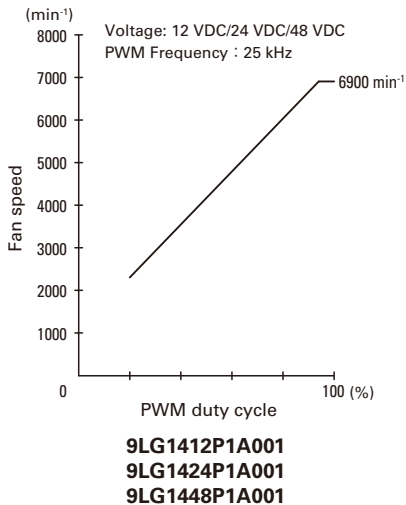

PWM Input Signal Example

Input signal waveform

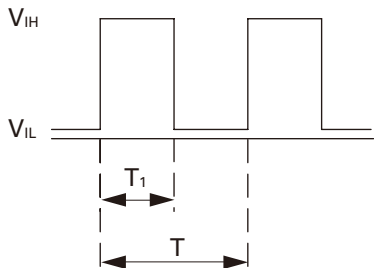

$V_{IH} = 4.75 \text{ to } 5.25 \text{ V}$ $V_{IL} = 0 \text{ to } 0.4 \text{ V}$
 $\text{PWM duty cycle (\%)} = \frac{T_1}{T} \times 100$ $\text{PWM frequency } 25 \text{ (kHz)} = \frac{1}{T}$
 Current source (I_{source}) = 1 mA max. (when control voltage is 0 V)
 Current sink (I_{sink}) = 1 mA max. (when control voltage is 5.25 V)
 Control terminal voltage = 5.25 V max. (when control terminal is open)

When the control terminal is open, fan speed is the same as when PWM duty cycle is 100%.
 Either TTL input, open collector or open drain can be used for PWM control input signal.

Example of Connection Schematic

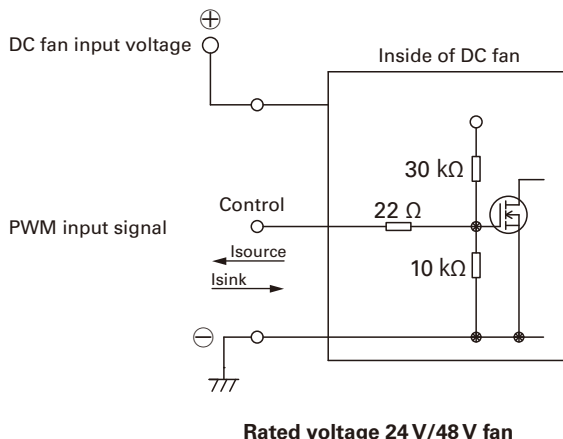
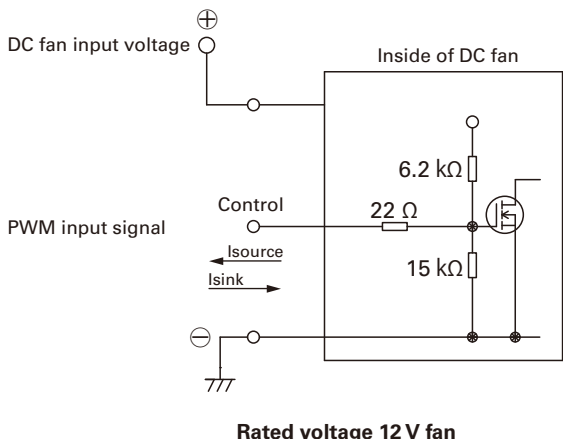

Specifications for Pulse Sensors

Output circuit: Open collector

Inside of DC fan

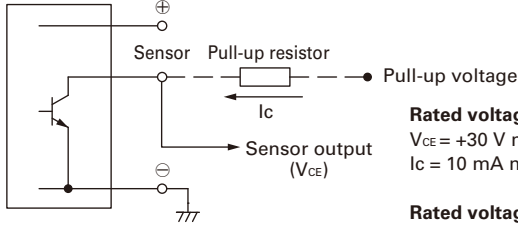

Rated voltage 12 V/24 V fan

$V_{CE} = +30 \text{ V max.}$

$I_C = 10 \text{ mA max. [} V_{OL} = V_{CE} (\text{SAT}) = 0.6 \text{ V max.]}$

Rated voltage 48 V fan

$V_{CE} = +60 \text{ V max.}$

$I_C = 10 \text{ mA max. [} V_{OL} = V_{CE} (\text{SAT}) = 0.6 \text{ V max.]}$

Output waveform (Need pull-up resistor)

In case of steady running

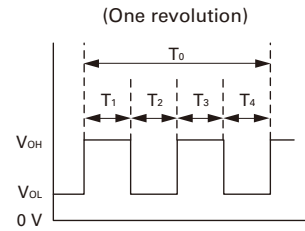

$T_{1 \text{ to } 4} \doteq (1/4) T_0$

$T_{1 \text{ to } 4} \doteq (1/4) T_0 = 60/4N \text{ (s)}$

$N = \text{Fan speed (min}^{-1}\text{)}$

Dimensions (unit: mm)

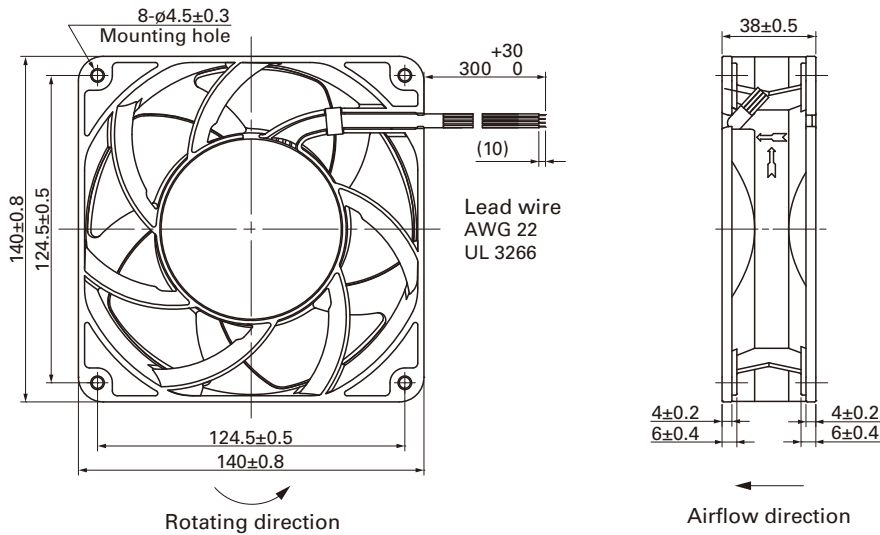

Reference Dimensions of Mounting Holes and Vent Opening (unit: mm)

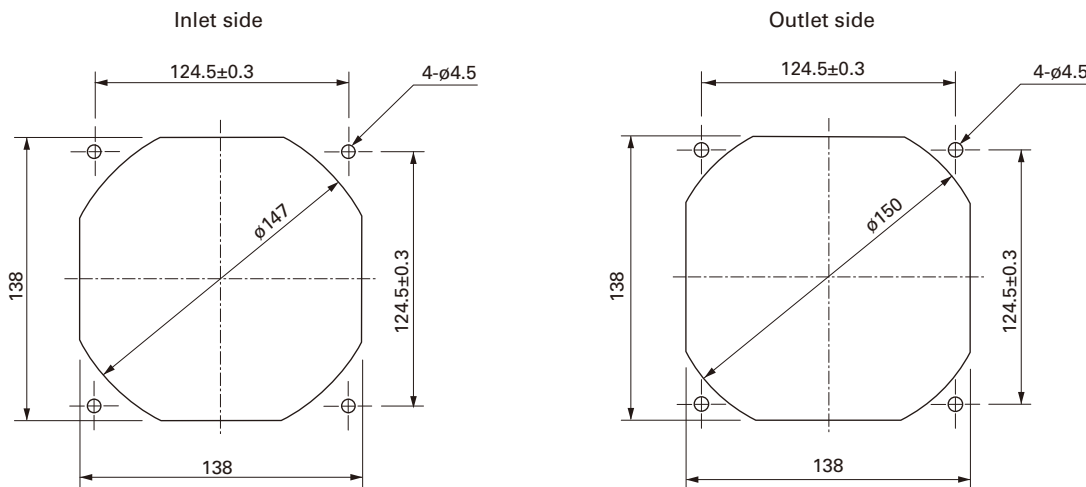

Notice

- Please read the "Safety Precautions" on our website before using the product.
- The products shown in this catalog are subject to Japanese Export Control Law. Diversion contrary to the law of exporting country is prohibited.
- For protecting fan bearings against electrolytic corrosion near strong electromagnetic noise sources, we provide effective countermeasures such as Electrolytic Corrosion Proof Fans and EMC guards. Contact us for details.

SANYO DENKI CO.,LTD. 3-33-1 Minami-Otsuka, Toshima-ku, Tokyo 170-8451, Japan TEL: +81 3 5927 1020

<https://www.sanyodenki.com>

The names of companies and/or their products specified in this catalog are the trade names, and/or trademarks and/or registered trademarks of such respective companies. "San Ace" is a trademark of SANYO DENKI CO.,LTD.

Specifications are subject to change without notice.

CATALOG No. C1079B001 '18.1