

SANMOTION Model No. PB

CLOSED LOOP STEPPING SYSTEMS

4-Axis, EtherCAT Integrated Driver for Closed Loop Stepping Systems

DC input

EtherCAT[®]
Conformance tested



Applications

Semiconductor manufacturing equipment, laser cutting machines, general industrial machinery

Features

High-speed fieldbus EtherCAT interface equipped

This driver comes equipped with a fieldbus¹ that allows for 100 Mbps high-speed and highly reliable communications. This has shortened the communication cycle time by 4 times² or more than that of our current model³, achieving finer and smoother motion of the embedded device.

Encoder variations available for simplified maintenance

In addition to an incremental encoder, a battery-less absolute encoder is also available. This encoder doesn't require a battery change, thus the maintenance of devices can be simplified.

Flexible system configuration

Different encoder types can be equipped with each motor axis, enabling configuration of systems matched to device structure.

The driver can automatically identify the encoder types, saving time on setup. (patent pending)

Shortens motion completion time of devices

Any commanded motion such as position settling and continuous rotation can be controlled without delays to position commands.⁴

¹ Fieldbus is an all-digital, serial communications protocol used for communications among field devices and to the controller.

² Minimum communication cycle time: 0.25 ms (1 ms for the below current model).

³ When compared with our current model PB4D003E2D0.

⁴ Low-deviation closed loop control.

Specifications

Basic specifications	Model no.	PB4D003E440		
	Interface	EtherCAT communication		
	Input power supply	Main circuit power supply: 24/48 VDC \pm 10%	Control circuit power supply: 24 VDC \pm 10%	
	Number of controllable axes	4 axes		
	Power supply current	14 A		
	Environment	Protection rating	Class III	
		Operating environment	Installation category (overvoltage category): I, Pollution degree: 2	
Mass	0.7 kg			
Functions	Max. motor speed	4500 min ⁻¹ , (3000 min ⁻¹ for 60 mm sq. motor)		
	Holding brake control function	Built in		
	Protection functions	Main circuit overcurrent, overload error, initialization error, driver overheat, main circuit overvoltage, regeneration error, main circuit undervoltage, control circuit undervoltage, encoder disconnection, overspeed error, position deviation error, wrap around, memory error, CPU peripheral circuit error, communication error		
	LED indicators	Power, Status, Alarm		
	Rotary switch	Station alias setting		
	Computer port	USB 2.0		
EtherCAT interface	Physical layer / protocol	100BASE-TX / IEEE802.3 Fast Ethernet		
	Bit rate	100 Mbit/s (Full duplex)		
	Communication port / Topology	RJ45 connector (2 ports) / Daisy chain (max. 65535 nodes)		
	Device profile	Device profile: CoE (IEC 61800-7-201), FoE (ASCII code access)		
	Synchronization mode	SM2 event synchronization, DC synchronization (SYNC0/SYNC1), non-synchronized (asynchronous FreeRun mode) Minimum cycle time: 0.25 ms		
I/O signal	Input signal	Photocoupler input method. Input resistance: 2.2 k Ω Input signal voltage: High-level: 4.0 to 26.4 VDC; Low-level: 0 to 1.0 VDC, Number of inputs: 16		
	Output signal	Open collector output by photocoupler. Output signal standard: Vceo = 4.75 to 26.4 V, Ic = 50 mA max. Number of outputs: 12		

Safety standards	CE (TÜV)	Directive	Standard	Name
		Low-voltage directive	EN 61800-5-1	—
		EMC directive	EN 61000-6-2, EN 61000-6-4, EN 61800-3	—
	UL	Organization	Standard	File No.
		UL	UL 508C	E179775
		cUL (UL for Canada)		
	KC (Korea Certification) mark		Standard	
		KN 61000-6-2, KN 61000-6-4		

Compatible motors & options

Motor flange size	28 mm sq.	42 mm sq.	60 mm sq.
Motor lineup	Standard model	Standard model	Standard model
	Spur gear model Gear ratio 1:3.6, 1:7.2, 1:10, 1:20, 1:30, 1:50	Low-backlash gear model Gear ratio 1:3.6, 1:7.2, 1:10, 1:20, 1:30	Low-backlash gear model Gear ratio 1:3.6, 1:7.2, 1:10, 1:20, 1:30
	Harmonic gear model Gear ratio 1:50, 1:100	Harmonic gear model Gear ratio 1:30, 1:50, 1:100	Harmonic gear model Gear ratio 1:50, 1:100
	Electromagnetic brake model	Electromagnetic brake model	Electromagnetic brake model
Encoder type	Optical incremental encoder	Optical incremental encoder, Optical battery-less absolute encoder	

Options

Item
Power cable
Connector set for power cable
Motor extension cable
Connector set for motor cable
Encoder extension cable
Connector set for encoder cable
I/O signal cable
Connector set for I/O signal cable
Regenerative unit

Dimensions

(Unit: mm)

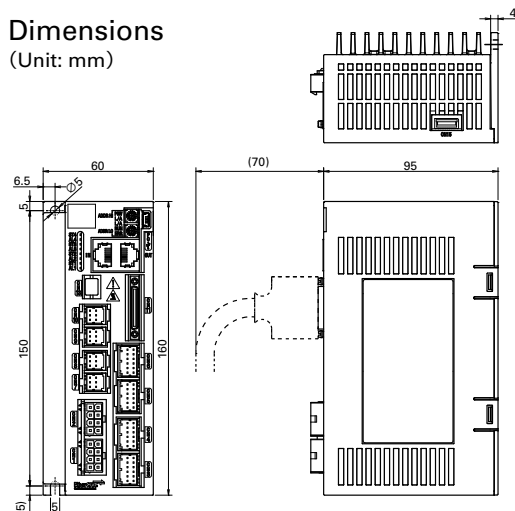

SANYO DENKI CO., LTD.

3-33-1 Minami-Otsuka, Toshima-ku, Tokyo 170-8451, Japan TEL: +81 3 5927 1020

<http://www.sanyodenki.com>

The names of companies and/or their products specified in this catalog are the trade names, and/or trademarks and/or registered trademarks of such respective companies.

Specifications are subject to change without notice.

CATALOG No. S1037B001 '17Z