

NO.	ECN NO.	DESCRIPTION	REV.	DRAW	DATE

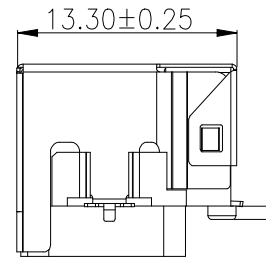
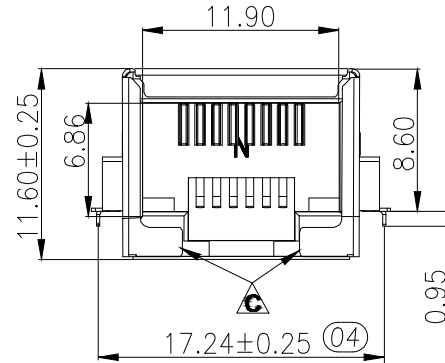
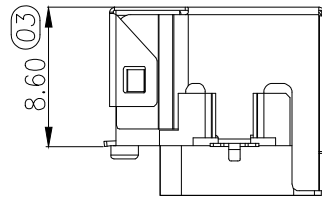
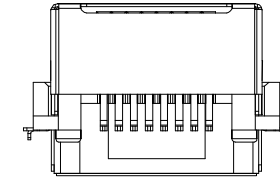
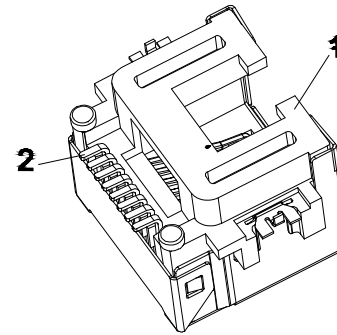
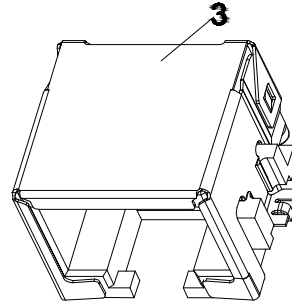
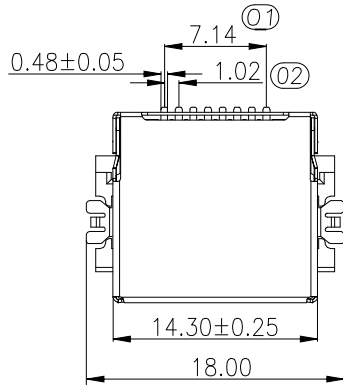

NOTES:

ELECTRICAL:

- VOLTAGE RATING : 125 VAC RMS.
- CURRENT RATING : 1.5 AMP.
- CONTACT RESISTANCE : 30 MILLIOHMS MAX.
- INSULATION RESISTANCE: 1000MEGOHMS MIN @ 500 VDC.
- DIELECTRIC STRENGTH: 1000 VDC RMS 60Hz, 1MIN.

MECHANICAL:

- HOUSING MATERIAL : NYLON UL94V-0./COLOR:BLACK
- CONTACT MATERIAL : PHOSPHOR BRONZE T=0.3mm.
- PLATING : F-GOLD PLATING OVER NICKEL.
- OPERATING LIFE : 750 CYCLES MIN.
- PCB RETENTION PRE-SOLDER: 1 LB MIN.
- PCB RETENTION POST-SOLDER: 10 LBS MIN.

ENVIRONMENTAL:

- STORAGE : -40°C TO +85°C.
 - OPERATION: +0°C TO +70°C.
- MATES WITH MODULAR PLUG CONFORMING TO FCC PART 68, SUBPART F.

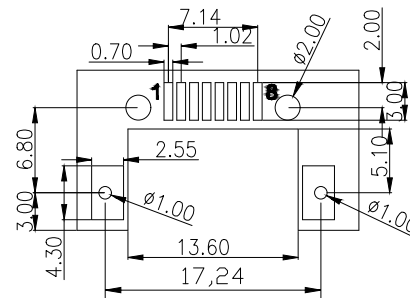
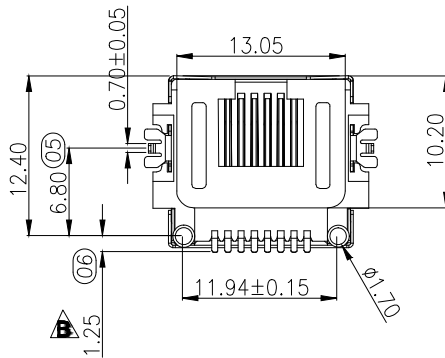

PCBLAYOUT TOP VIEW

TOL ±0.05

TOLERANCE		APPS Electronics Limited				
.X ±0.25	X.° ±2°	 APPS Electronics Limited				
.XX ±0.15	.X° ±1°					
.XXX ±0.075						
SCALE	1:1	PROJ.	DESIGN	TITLE	RJ45 SMD Lowprofile 3.0mm	
SHEET	1/1	SIZE	A4	CHECKED	ITEM NO.	AE-RJC102Z03
UNIT	mm	REV.	A	APPROVE	DWG NO.	