

80mm sq.

San Ace 80

15mm thick (GA type), 15mm thick, 20mm thick (GA type),
 20mm thick, 25mm thick (GA type), 25mm thick (S type)
 25mm thick (GV type), 25mm thick
 25mm thick (San Cooler), 32mm thick (GA type)
 32mm thick, **38mm thick (HV type)**, 38mm thick (GA type)
 38mm thick (GV type), 38mm thick (G type)



General Specifications

- Material Frame: Plastics (Flammability: UL94V-0),
 Impeller: Plastics (Flammability: UL94V-0)
- Expected Life Refer to specifications (L10:Survival rate:90% at 60°C ,
 rated voltage, and continuously run in a free air state)
- Lead Wire ⊕red ⊖black or blue (Sensor) yellow
- Storage Temperature -30°C to +70°C (Non-condensing)

80×80×38mm (Mass : 230g) **HV type**

Specifications

The following nos. **have PWM controls, pulse sensors, and ribs.** For ribless, append "1" to the model no.

Model No.	Rated Voltage [V]	Operating Voltage Range [V]	PWM duty cycle※ [%]	Rated Current [A]	Rated Input [W]	Rated Speed [min ⁻¹]	Max. Air Flow [m ³ /min] [CFM]	Max. Static Pressure [Pa] [inchH ₂ O]	SPL [dB(A)]	Operating Temperature [°C]	Expected Life ^{nom} [h]
9HV0812P1G001	12	10.8 to 13.2	100	3.4	40.8	14,900	3.7 130.7	1,000 4.0	69	-20 to +70	40,000/60°C (70,000/40°C)
			0	0.64	7.68	4,400	1.06 37.5	87.2 0.35	40		
9HV0848P1G001	48	36 to 57	100	0.85	40.8	14,900	3.7 130.7	1,000 4.0	69	-10 to +70	40,000/60°C (70,000/40°C)
			0	0.13	6.24	4,400	1.06 37.5	87.2 0.35	40		

Note: Expected life at 40°C ambient is just reference value.

※PWM Frequency : 25kHz

- Available options: ⇒ **Without Sensor** **Pulse Sensor**
- Please inquire as the availability of these functions depend on the model. ⇒ **Lock Sensor**

Dimensions (Unit : mm) (With ribs)

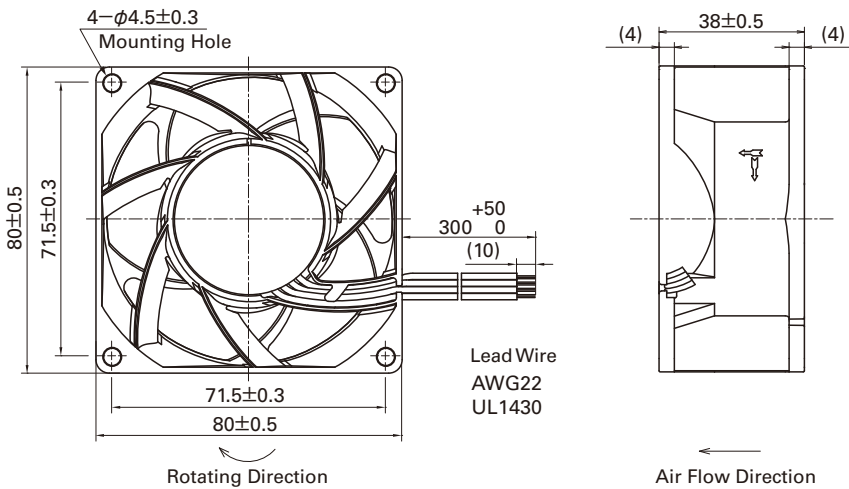

Options (Unit : mm)

Finger guards

Model : 109-049C Surface treatment : Nickel-chrome plating (silver) Color

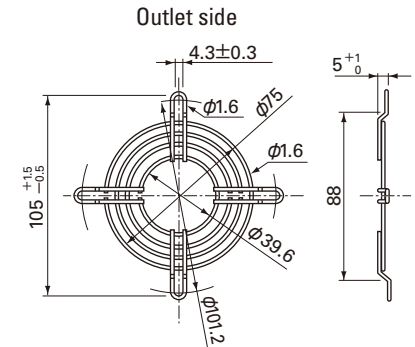

Model : 109-049E Surface treatment : Nickel-chrome plating (silver) Color (silver)
 : 109-049H : Cation electropainting (black)

Reference dimension of mounting holes and vent opening (Unit : mm)

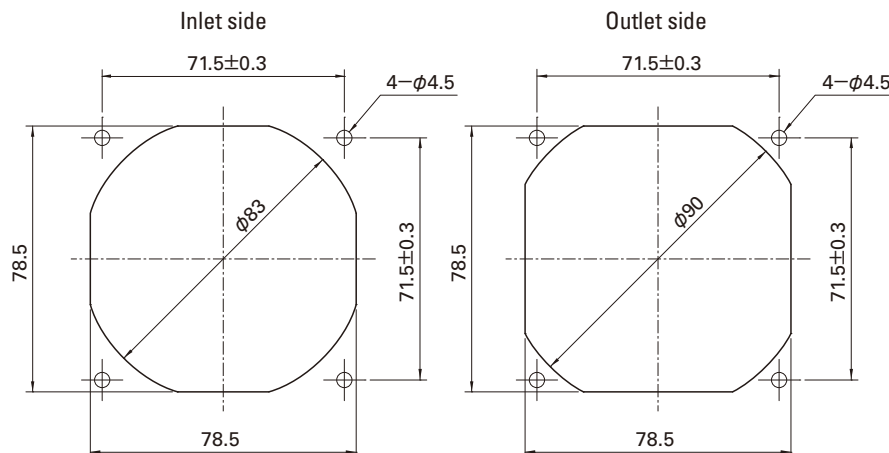

Inlet side, Outlet side

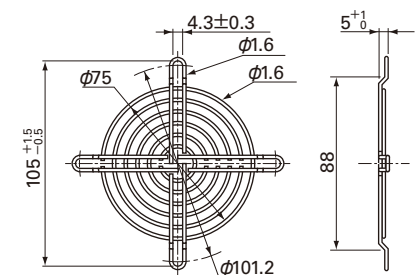

Options (Unit : mm)

Resin finger guards

Model : 109-1002G

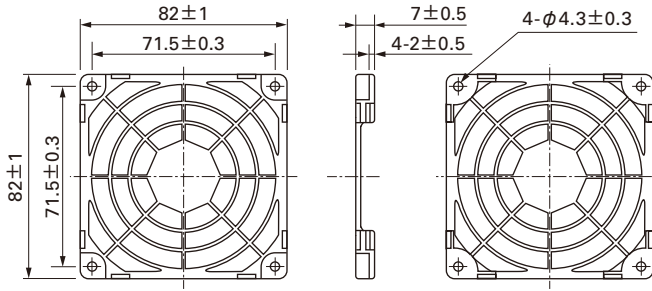

Resin filter kits

Model : 109-1002F13 (13PPI), 109-1002F20 (20PPI)
: 109-1002F30 (30PPI), 109-1002F40 (40PPI)

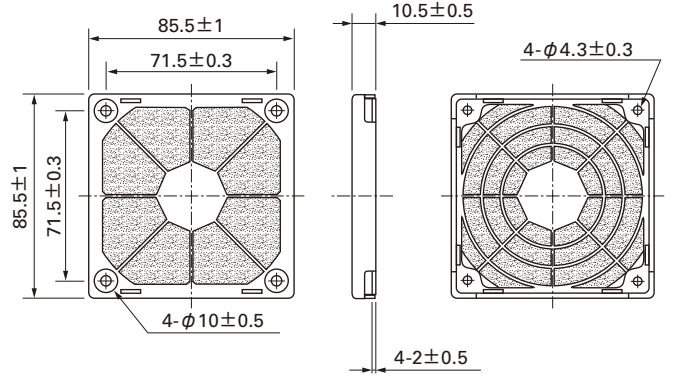

Air Flow - Static Pressure Characteristics

PWM Duty Cycle

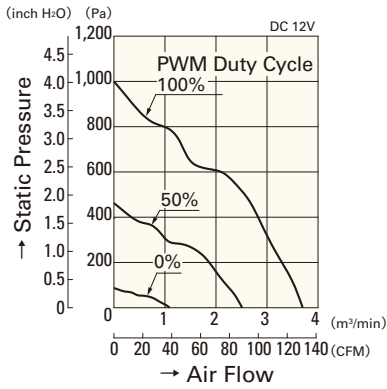

9HV0812P1G001

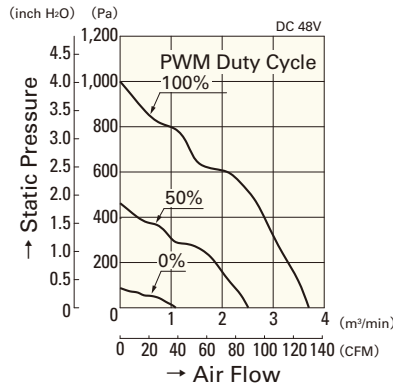

9HV0848P1G001

Operating Voltage Range

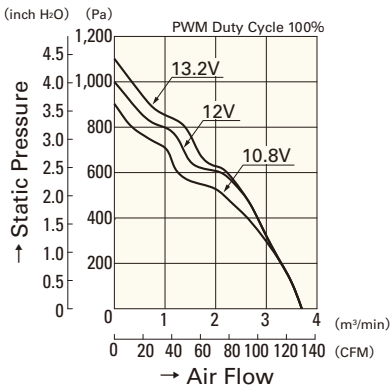

9HV0812P1G001

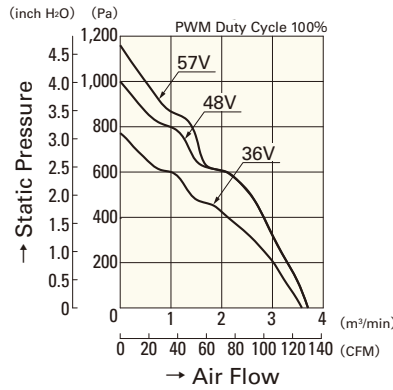

9HV0848P1G001

PWM Duty - Speed Characteristics Example

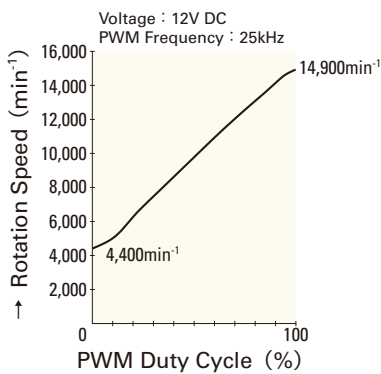

9HV0812P1G001

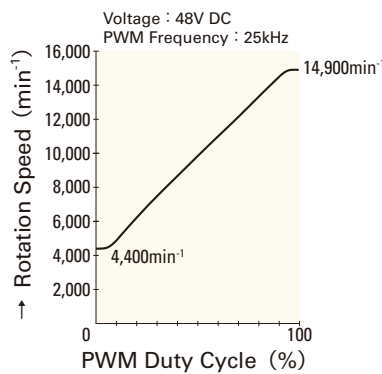

9HV0848P1G001