

PRODUCT NO
SEE TABLE

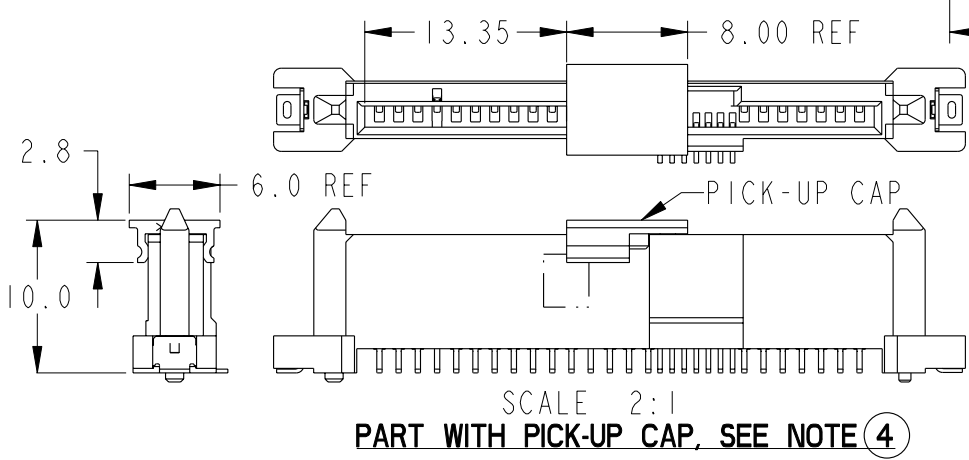

spec ref	-	dr	GL LOO	2009-09-23	projection	MM	size	A3	scale	3:1	
tolerance std	ISO 406 ISO 1101	eng	GL LOO	2009-09-23			ecn no	S11-0019			
TOLERANCES UNLESS OTHERWISE SPECIFIED		chr	GL LOO	2011-09-01			product family	SAS	rel level	-	
surface	ISO 1302	appr	JOEY NG	2011-09-01	SAS RECEPTACLE VERTICAL SMT TYPE ASSY			dwg no	10107271	rev	B
	linear	0.X	±		www.fci.com			cat. no.	-	CUSTOMER	sheet 1 of 2
		0.XX	±0.20								
		0.XXX	±								
	angular	0°	±2°								

Copyright FCI.

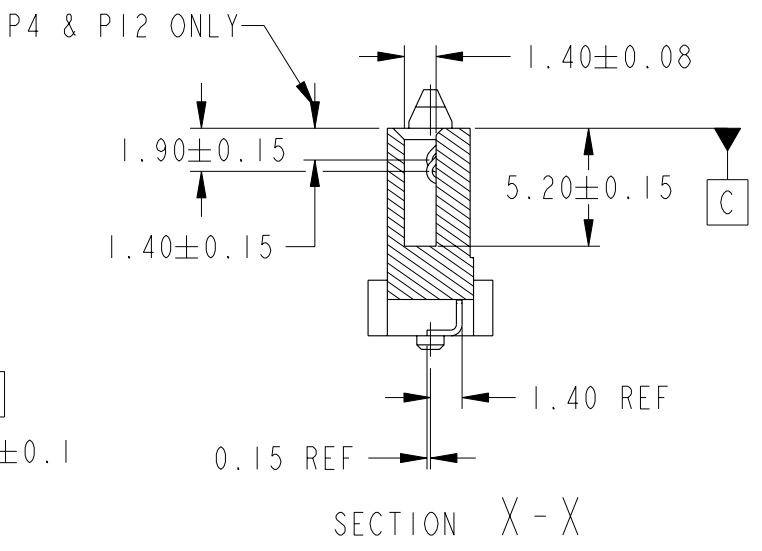
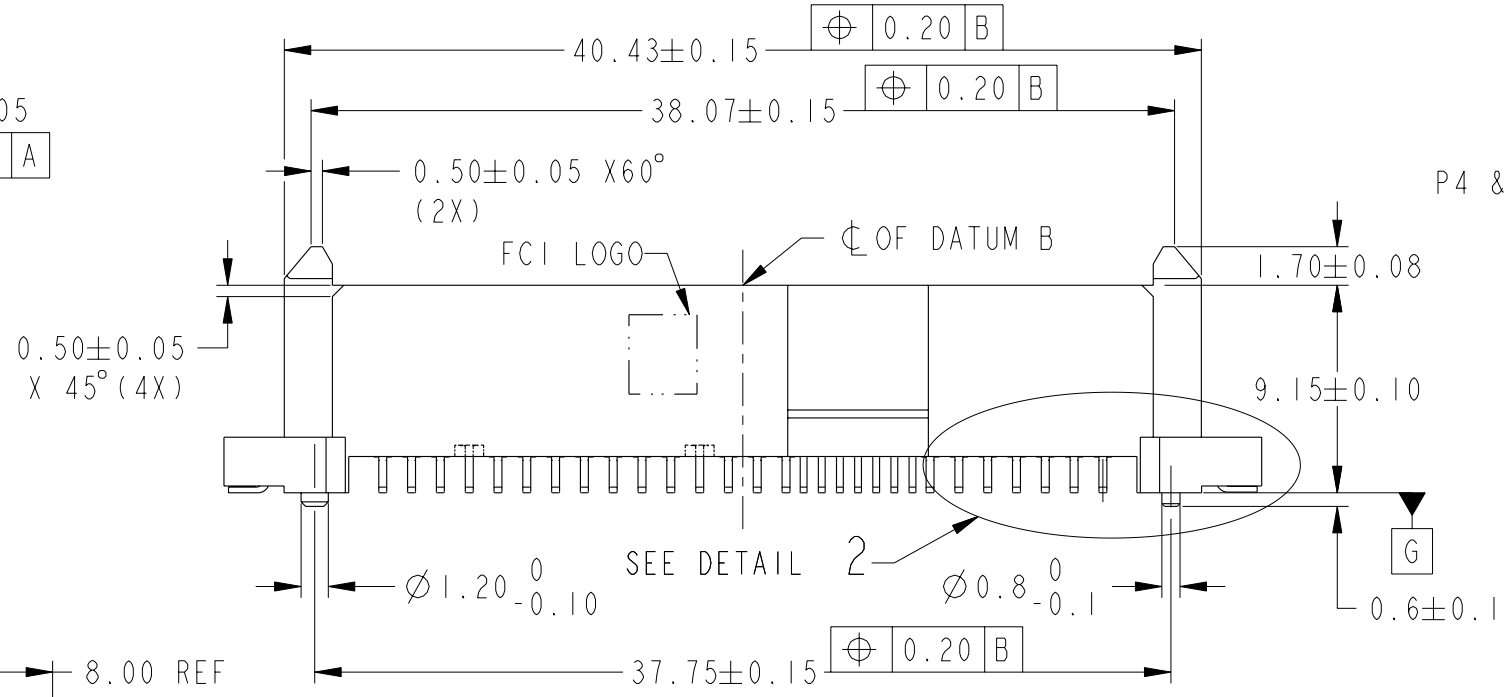
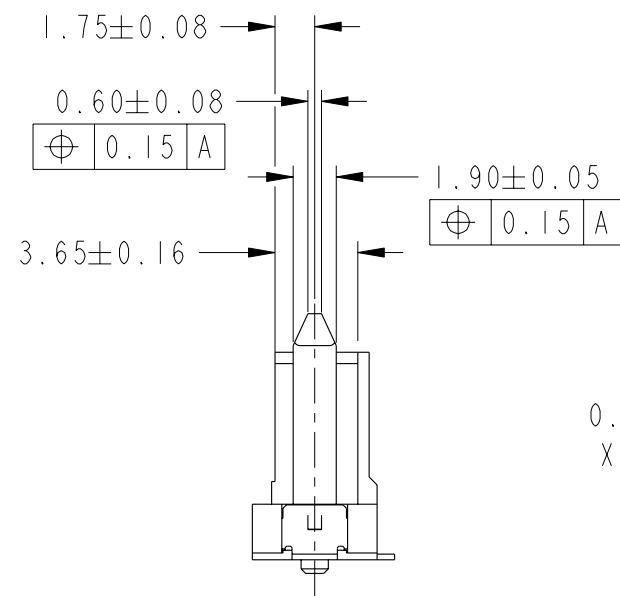
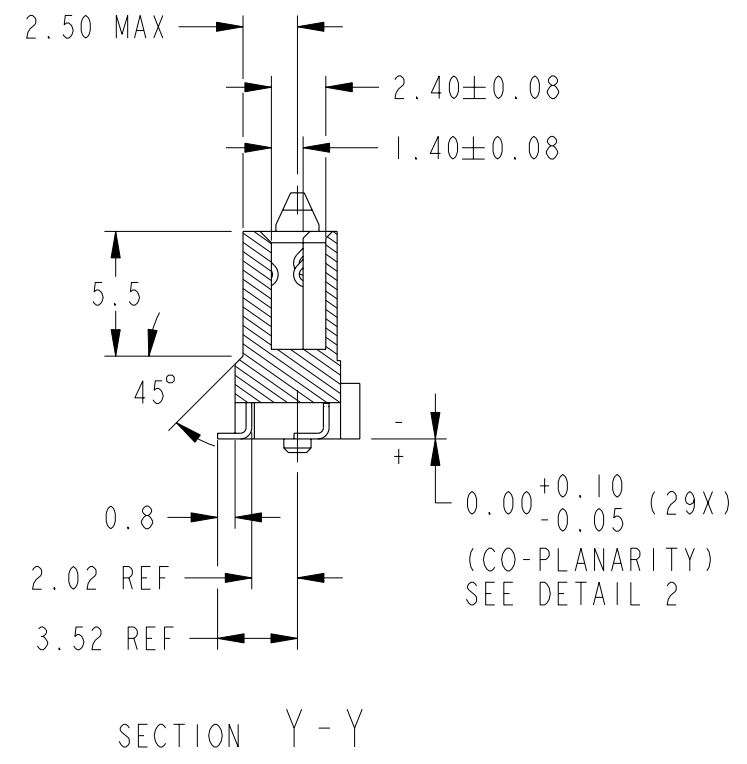
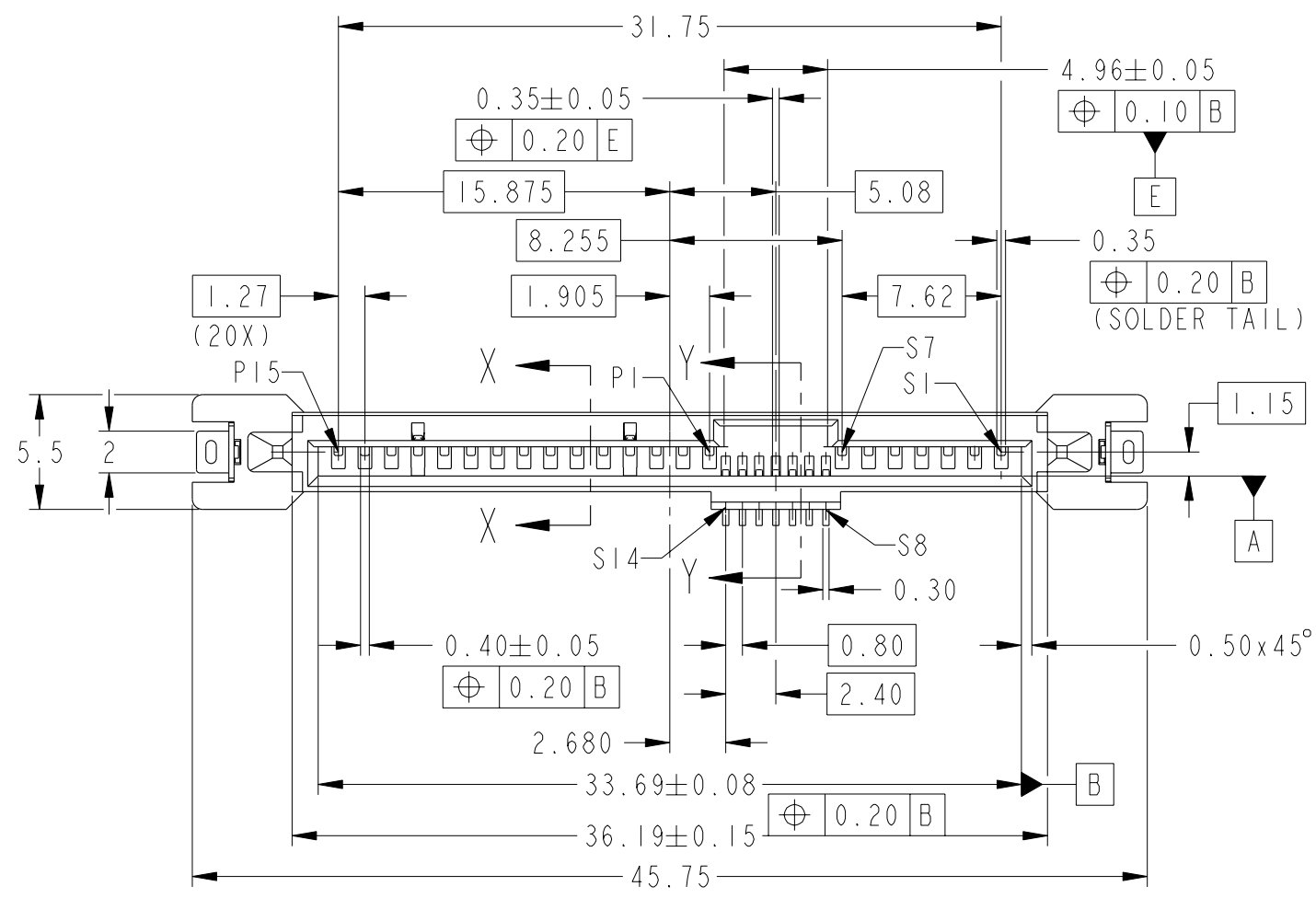